

HARRIS®

BRAZING & SOLDERING PRODUCT GUIDE





BRAZING & SOLDERING

PRODUCT GUIDE

The HARRIS Products Group	4-5
Phos/copper alloys	6-7
High Silver Content Brazing alloys, solders and Fluxes	8
Cadmium bearing alloys	8
Cadmium free alloys	9
Ternary silver alloys	10
Soldering	11
Aluminium	12
Fluxes	13
Welding	14



The Harris Products Group is a global manufacturer of high quality soldering, brazing and welding filler metals. Harris filler metals are used by many different industries including appliances, equipment manufacturing, air conditioning, refrigeration, plumbing, welding, tooling, automotive, and construction. Throughout our history, we have developed and manufactured products to the highest standards for brazing alloys leading the industry in quality.

Harris brazing alloys are manufactured from the cleanest, purest base metals using exclusive manufacturing technology developed by our engineering staff. These processes ensure that every alloy is free of impurities.

The Harris Products Group was officially formed on May 1, 2006, with the combination of Gainesville, Georgia-based Harris Calorific, Inc. and Mason, Ohio-based J.W. Harris Company.

Harris Calorific is a manufacturer of gas welding and cutting equipment, industrial and specialty gas regulation equipment, and gas distribution systems. J.W. Harris, on the other hand, is a manufacturer of brazing and soldering alloys and welding consumables.

The merger resulted from a series of acquisitions by The Lincoln Electric Company, starting with the purchase of Harris Calorific in 1990 and followed by the addition of J.W. Harris in 2005. Also, included in the J.W.Harris acquisition was Autobraze, a manufacturer of precision brazing rings and return bends utilized in the HVAC industry. Later in 2005, Lincoln acquired Gulf Wire Corporation, a manufacturer of aluminium and stainless welding consumables,



Harris Calorific



J.W. Harris



The Harris
Products Group

and Filler Metals, a supplier of niche welding alloys. In 2008, Harris purchased Brastak a manufacturer of brazing alloys, in Sao Paulo, Brazil.



JW Harris has operated since 1914.

The practices we have used for serving our customers and industries continue as we innovate and grow into the future.

The Harris Products Group has the knowledge, experience and production capacity to give you a strong partner who will make your metal joining operations more profitable.



Phos/copper alloys

Phos/copper alloys are used to braze copper to copper and copper to brass. The phosphorous content in these alloys makes them self-fluxing on copper. When brazing brass or copper to brass, use Stay-Silv® white brazing flux. These alloys are not recommended for brazing steel or other ferrous metals.



The amount of phosphorous in the phosphorous /copper filler metals is the critical factor that determines the melting range of the alloys and thus, how they perform.

The Harris Products Group is the brazing industries forerunner in developing the technology to control phosphorous content.

This controls alloy melting temperatures so exactly, that brazing operators no longer need to make temperature adjustments from one bath of filler metals to the next.

Operators know that with Harris alloys, the result will be the same with every bath, every time.

Its technology is so precise that The Harris Products Group guarantees users a Liquidus temperature variation of no more than ± 3.3 °C,

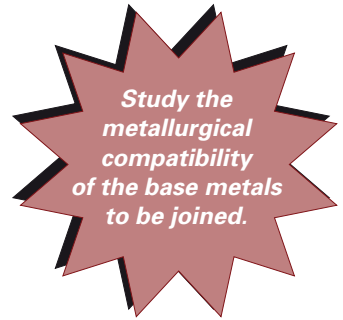

and a much tighter standard than industry requires. Every package of Harris brazing alloy is clearly marked with alloy identification. Over the decades many things have changed in our industry. But our dedication to making the world's purest and most consistent brazing alloys has not changed; we are committed to giving you the best tool to do your job.

All alloys are available in rods, solid wires and rings in both metric and imperial sizes according to European and American standards.

Alloy	EN-1044	Cu %	P %	Ag %	Sn %	Other %	Melting range °C	Specific Weight gr/cm ³	Fluidity Rating
L-CuP6	CP 203	Bal	5,9 - 6,5	-	-	0,25	710 - 890	8,10	4
L-CuP7	CP 202	Bal	6,6 - 7,4	-	-	0,25	710 - 820	8,05	6
L-CuP8	CP 201	Bal	7,5 - 8,1	-	-	0,25	710 - 770	8,00	8
L-CuSn7	CP 302	Bal	6,4 - 7,2	-	6,5 - 7,5	0,25	650 - 700	8,00	-
Harris [®] 0	-	Bal	7,1 - 7,1	-	-	0,25	710 - 802	-	5
Phoson	-	Bal	7,3 - 7,3	-	-	0,25	732 - 815	-	-
Blockade [®]	-	Bal	-	0,08 - 0,12	-	0,25	637 - 673	-	-
L-Ag2P	CP 105	Bal	5,9 - 6,7	1,50 - 2,50	-	0,25	645 - 825	8,00	3
L-Ag5P	CP 104	Bal	5,7 - 6,3	4,50 - 5,50	-	0,25	645 - 815	8,10	4
L-Ag6P	CP 103	Bal	7,0 - 7,6	5,80 - 6,20	-	0,25	645 - 725	8,20	4
L-Ag15P	CP 102	Bal	4,7 - 5,3	14,5 - 15,5	-	0,25	645 - 800	8,40	4
L-Ag18P	CP 101	Bal	6,6 - 7,5	17,0 - 19,0	-	0,25	645 - 645	8,60	-
Dynaflow [®]	-	Bal	6,1 - 6,1	6,00 - 6,00	-	0,25	643 - 796	-	3

High Silver Content Brazing alloys, solders and fluxes

Minimize the structural stress using low brazing temperatures.

The Harris Products Group manufactures their complete line of cadmium-free, high silver brazing alloys with the same attention to quality found in their phos/copper products. Only the purest metals are used, and precision production procedures ensure consistency in product quality and performance.



Cadmium bearing alloys

The cadmium bearing alloys are used to make joints in ferrous and non ferrous alloys, excluding stainless steel.

The Harris Products Group cadmium bearing alloys have a low melting range, suitable to make joints where the temperature needs to be controlled. High silver cadmium bearing alloys have lots of industrial applications only constrained by the regulations limiting the use of cadmium . (RoHs, Reach).

All alloys are available in bare rods, flux coated rods, solid wires and rings in both metric and imperial sizes according to European and American standards.

Alloy	EN-1044	Ag %	Cu %	Zn %	Cd %	Melting range °C	Specific Weight gr/cm ³
L-Ag20Cd	AG 309	20	40	25	15	605 - 765	8,8
L-Ag25Cd	AG 307	25	30	27	18	605 - 720	8,8
L-Ag30Cd	AG 306	30	28	21	21	600 - 690	9,2
L-Ag35Cd	AG 305	35	26	21	18	610 - 700	9,1
L-Ag40Cd	AG 304	40	19	21	20	595 - 630	9,3
L-Ag45Cd	AG 302	45	15	17	23	605 - 620	9,4
L-Ag50Cd	AG 301	50	15	17	18	620 - 640	9,5

Cadmium free alloys

The high tin silver alloys are recommended to make joints in ferrous and non ferrous metals, including stainless steel. Ductility is high, corrosion resistance suitable for all but strong chemical applications.

Tin can effectively reduce the brazing temperature and is used to replace zinc or cadmium in filler metals.

These alloys have the limited melting range of high silver alloys; this feature offers advantages when the base material may not be overheated.

In all cases it is necessary to use flux like Stay Silv® White flux.



All alloys are available in bare rods, flux coated rods, solid wires and rings in both metric and imperial sizes according to European and American standards.

Alloy	EN-1044	Ag %	Cu %	Zn %	Sn %	Melting range °C	Specific Weight gr/cm ³
L-Ag25Sn	AG 108	25	40	33	2	680 – 760	8,7
L-Ag30Sn	AG 107	31	37	30	2	665 – 755	8,8
L-Ag34Sn	AG 106	34	36	27	3	630 – 730	9
L-Ag40Sn	AG 105	40	30	28	2	650 – 710	9,1
L-Ag45Sn	AG 104	45	27	25	3	640 – 680	9,2
L-Ag55Sn	AG 103	55	21	22	2	630 – 660	9,4
L-Ag56Sn	AG 102	56	22	18	5	620 – 655	9,4
L-Ag60Sn	AG 101	60	23	14	3	620 – 685	9,6

Ternary silver alloys

The ternary high silver alloys are recommended to make joints in ferrous and non ferrous metals, including stainless steel. Ductility is high, corrosion resistance suitable for all but strong chemical applications.

Tests have shown that joints brazed with silver-based filler alloys are used successfully for engine components which have service conditions up to 427°C.

Braze stainless steel with silver filler metals to prevent corrosion beside the affected thermal zone.

All alloys are available in bare rods, flux coated rods, solid wires and rings in both metric and imperial sizes according to European and American standards.

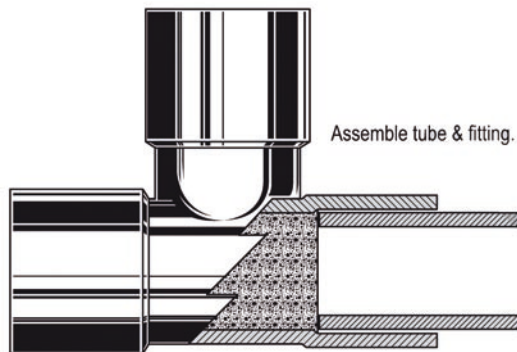

Alloy	EN-1044	Ag %	Cu %	Zn %	Sn %	Melting range °C	Specific Weight gr/cm ³
L-Ag5	AG 208	5	55	40	-	820 - 870	8,4
L-Ag12	AG 207	12	48	40	-	800 - 830	8,5
L-Ag20	AG 206	20	45	35	-	690 - 810	8,7
L-Ag25	AG 205	25	41	34	-	700 - 790	8,8
L-Ag30	AG 204	30	38	32	-	680 - 765	8,9
L-Ag44	AG 203	44	30	26	-	675 - 735	9,1
L-Ag60	AG 202	60	26	14	-	695 - 730	9,5

Soldering

Soldering alloys may be divided in 2 subfamilies:

- Lead free solders (Rohs compliant)
- Common solders.

The lead free solders, together with common solders, have the lowest melting point of brazing filler metals. These alloys may be used with dissimilar metal joints and vibration applications. Soldering alloys are especially effective in filling loosely fitted couplings. Use soldering alloys for all metals with the exception of aluminium.

Soldering filler metals are excellent for many HVAC connections, including manufacturing and plumbing.



Alloy	Sn %	Ag %	Cu %	Pb %	Ni %	Sb %	Melting range °C
Stay-Brite® 8	94	6	-	-	-	-	221 - 279
Stay-Brite®	96	4	-	-	-	-	221 - 221
Bridgit®	Bal	0,15	2,5 - 3,5	-	0,05 - 2	4,5 - 5,5	238 - 332
Nick®	Bal	0,05 - 0,15	3,5 - 4,5	-	0,15 - 0,25	-	225 - 387
Speedy®	Bal	-	2,5 - 3,5	-	-	-	232 - 290
95/5	95	-	-	-	-	5	233 - 240
40/60	40	-	-	60	-	-	182 - 238
60/40	60	-	-	40	-	-	182 - 191
50/50	50	-	-	50	-	-	182 - 216

Aluminium

When selecting a filler metal, choose one with a liquidus point at least 24-38°C below the base metal solidus.

Aluminum filler metals are recommended to join brazeable aluminum base metals because they melt below the solidus temperature. Brazing is the first developed procedure for making successful aluminium joints.

Aluminium alloys are an essential element in modern industry.



Alloy	Al %	Si %	Mg %	Zn %	Sn %	Other %	Melting range °C
Al-braze® 1070	88,00	12,00	-	-	-	0,15	577 - 582
Alcor®	2,00	-	-	98,00	-	0,15	440 - 440
Coral®	Bal	6,00	6,00	0,50	-	0,50	568 - 623
Alsolder® 500	-	-	-	15,00	85,00	0,15	199 - 250
ZnAl22	22,00	-	-	78,00	-	0,15	415 - 475
ZnAl2	2,00	-	-	98,00	-	0,15	420 - 480
4043	95,00	5,00	-	-	-	1,00	575 - 630
4047 (718)	88,00	12,00	-	-	-	1,00	575 - 585

Fluxes

Brazing flux promotes the achievement of a brazed joint by protecting the base metals and filler metal from oxidation. The brazing flux absorbs oxides formed during heating and promotes the flow of filler metal.

All parts prior to brazing must be subjected to the appropriate cleaning operations.



All fluxes are available in different weights and packaging. Please ask your distributor for more information.

Alloy	Active Range	Applications
Stay-Clean [®] Liquid Soldering Flux	Up to 371°C	For all base materials other than Al, Mg or Ti.
Stay-Clean [®] Paste Soldering Flux	Up to 371°C	For all base materials other than Al, Mg or Ti.
Stay-Silv [®] White Brazing Flux	566 - 871	Common flux to be used with ferrous and nonferrous alloys.
Stay-Silv [®] Black Brazing Flux	566 - 982	Recommended for stainless steel
Dynaflow [®] Brazing Flux	566 - 871	Excellent joint penetration, ferrous and nonferrous alloys.
Bridgit [®] Burn Resistant Flux	93 - 427	Designed to be used in lead free soldering.
Bridgit [®] Water Soluble Flux	121 - 315	Designed to be used in lead free soldering.
Al Braze [®] flux	500 - 700	Flux designed to be used in aluminium joints 4043 / 4047

Welding

Arc welding is a process developed to give more simplicity and more speed to traditional welding processes.

Arc process:

MIG MAG: MIG MAG process consists in welding without interruption, using solid wire with automatic input.

MMA: Manual electrode process, this is the first arc welding process developed.

TIG: TIG was designed to get high quality joints.

This is based on the input of a solid rod using an electric arc made by air ionization.



Alloy	Din	Material Number	Applications
Al 4043	1732 SG Al Si 5	3,2245	Silicon Aluminium joints
Al 4047	1732 SG Al Si 12		Silicon Aluminium joints
Al 5183	1732 SG Al Mg 5	3,3556	Magnesium Aluminium joints
308 L	8556 SG X 2 Cr Ni 19 9	1,4316	Stainless steel joints
309 L	8556 SG X 15 Cr Ni Mn 18 8	1,4370	High mechanical characteristics joints
312 L	8556 SG X 10Cr Ni 30 9	1,4337	High tension resistance joints
316 L	8556 SG X 2 Cr Ni 19 12	1,4430	Stainless steel joints
Silicon	1733 SG Cu Si 3	2,1461	Copper and copper alloys joints
Bronze			
Aluminium	1733 SG Cu Al 8	2,0921	Copper aluminium joints
Bronze			

PROFESSIONAL PRODUCTS ...SUPERIOR RESULTS



Harris Euro S.L.U.

C/ Arq. Ricard Giralt s/n Nave 6
17600 Figueres (Girona) - Spain

Tel: +34 972 67 88 26

Fax: +34 972 50 51 43

harriseuro@harriseuro.com

www.harrisproductsgroup.com



ACCREDITED BY ENAC



ACCREDITED BY IAF